

Geothermal Plant in Thisted with absorption heat pump and 10 years operation without corrosion or reinjection problems in sandstone for 15% saline water

Allan Mahler

Dansk Olie og Naturgas A/S,
 Agern Alle 24-26, 2970 Hørsholm, Denmark, fax.: 45171044, phone: 45171470
 Key words: Combined, Absorption, Injection, Sandstone, Saline

ABSTRACT

A geothermal pilot plant with an electric heat pump was erected by Dansk Olie og Naturgas A/S in 1984 and expanded to the present demonstration plant with an absorption heat pump in 1988. The use of an absorption heat pump nearly eliminates energy consumption and operation costs for the heat pump. The absorption heat pump is by now driven by heat from a combined heat and power incineration plant and the driving heat is fully recovered on the district heating network. The design has made it possible to avoid corrosion problems and to reinject millions of cubic meters of a 15% saline geothermal water in a sandstone reservoir. Heat production costs, plant concept, operating experiences and absorption heat pump concept are discussed. The reservoir temperature at 1250 m is 46°C and the transmissivity 100 Dm.

1. INTRODUCTION

The wells and the expansion of the pilot plant to the present demonstration plant were supported by EU - the expansion under GE/301/85-DK.

Denmark has no volcanic activities and no hot springs, but many reservoirs with warm geothermal water which can be used for district heating. The normal temperature increase with depths is 0.025-0.033°C per meter. The geothermal resources exceed the energy needed for heating in Denmark for hundreds of years but they are only exploitable in a limited number of towns. The possibility of producing electricity based on hot geothermal water from deep reservoirs has been investigated, but reservoirs with sufficiently low pumping costs have not been found in Denmark.

The geothermal plant produces heat to a district heating network, which receives heat from the geothermal plant, an incineration based heat and power plant and gas boilers.

The geothermal plant uses absorption heat pumps to transfer the heat and it has thus very low operation costs, but the heat demand in Thisted is not big enough for the production from both the geothermal plant and the combined heat and power plant.

This does not lead to a satisfactory economy for the plant, but the operation experience is otherwise very good and it can be used to calculate heat production costs in towns with bigger heat demands.

2. BACKGROUND

Dansk Olie og Naturgas A/S was granted a sole concession for the exploration and production of geothermal energy in Denmark in 1978 and has worked with geothermal energy since. One third of the concession area was given back to the state in 1993.

The geothermal potential in Denmark was investigated through seismics, investigation of oil- and gas wells and the drilling of

geothermal exploration wells. A computer program was also developed for the evaluation and optimization of plant concepts and for the calculation of the energy consumption and heat production costs for geothermal plants.

When the exploration started, the goal was to find approx. 100°C hot geothermal water and extract the heat by direct heat exchange. Three geothermal explorative wells were drilled to 3 km depth and 100°C warm water was found, but the permeability was too low.

It was thus decided to abandon the concept of direct heat exchange with water produced from deep wells and instead use more permeable reservoirs closer to the surface and heat pumps.

3. GEOTHERMAL PLANT IN THISTED

The geothermal plant in Thisted is based on heat transfer through heat pumps and a high permeable 46°C warm reservoir at 1250 m depth in the last drilled explorative well. A deeper 63°C reservoir was also tested, but not chosen due to a high fines content and risk of fines migration.

The Phases of the Thisted Project are listed below:

- Phase 1: Production Well, Contract GE 78/81, 4/2-1982 to 14/2-1985. Drilling, test and completion of the production well. The production well was drilled to a depth of 3287 m, tested, plugged at approx. 1300 m and gravel packed at the Gassum reservoir at 1250 m.
- Phase 2: Injection Well, Contract GE 148/83, 8/8-1983 to 1/4-1985. Drilling, test and completion of the injection well. The well was drilled to a depth of 1242 m, tested and gravel packed at the Gassum reservoir at 1200-1250 m.
- Phase 3: Pilot Plant, not supported by EEC, 1/9-1983 to 1/10-1986. Design, erection and test/production for 1.26 MW pilot plant. Electrical heat pump from Sabroe transferred 1.26 MW heat to the district heating network in Thisted. The heat pump heated district heating water to approx. 70°C cooling 30 m³/h, 42°C brine to approx. 14°C.
- Phase 4: Demonstration Plant, Contract GE 301/85, 8/11-1985 to 31/12-1988. Design, erection and test of Demonstration Plant. Expansion of the geothermal brine loop from 30 m³/h to 140 m³/h and erection of new heat pump plant with absorption heat pump plant.
- Phase 5: Demonstration phase, Contract GE 301/85. Very satisfactory technical performance, but insufficient heat demand due to expansion of incineration plant.

3.1 Pilot plant

A geothermal pilot plant with a 1.26 MW electric heat pump was erected in Thisted in 1984 with production from and reinjection to the Gassum reservoir at 1250 m depth. The produced heat goes to a district heating network.

The pilot plant proved a concept for avoiding corrosion and damage of the injection well, but a reduction of electricity costs for the heat pump was **needed** and different alternatives were investigated. It was concluded that the plant should be equipped with an absorption heat pump when the plant was expanded to a demonstration plant in 1988.

3.2 Demonstration plant

The demonstration plant in Thisted with the electric and the absorption heat pump started operating in 1988. In 1994 the electric heat pump was removed.

The geothermal heat is transferred to the district heating network at Thisted by the LiBr absorption heat pump which is driven by 150-160°C hot water from boilers and a combined heat and power incineration plant.

77 of the heat used to operate the absorption heat pump is recovered on the district heating network together with the extracted geothermal heat. The driving heat for the absorption heat pump is borrowed and returned - and thus free if the driving heat normally goes direct to the district heating network.

The plant now extracts up to 3.5 MW heat with the absorption heat pump alone from 145 m³/h of a 46°C, 15% saline geothermal water. The geothermal water is produced from and reinjected in the 100 Dm Gassum sandstone reservoir. A schematic of the plant is shown in Fig. 1.

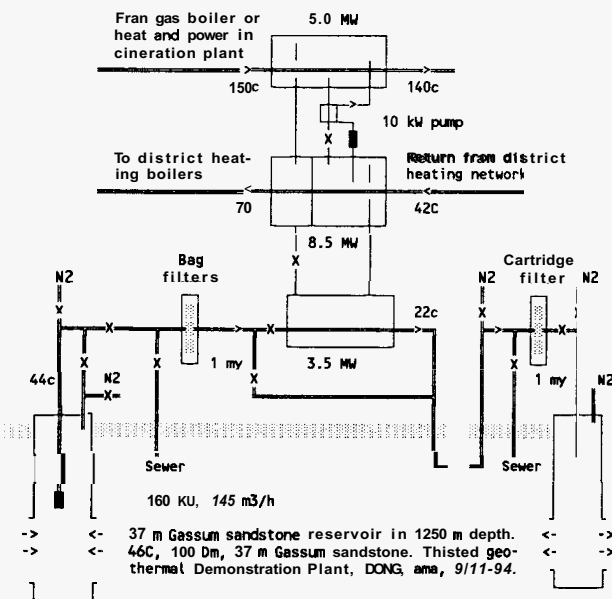

Fig. 1 : Thisted Geothermal Plant

The plant is designed with:

- Carbon steel tubes (diffusion proof and even distribution of corrosion).
- Corrosion resistant materials at selected places (e.g. balls in ball valves).
- Filtering of geothermal water to one micron (1/1000 mm) in bag and cartridge filters.

Recirculation valve on production well reducing start and sewer flow.

- Avoidance of low pressures from Bernoulli effects when operating.
- Nitrogen bottles securing over pressure during stops.
- Gravel packs in production and injection well.
- Computer controlled fail safe valves.
- Suitable equipment and wells.

Geothermal plant in Thisted with clean up basin, wellhead shelter, geothermal plant, heat accumulation tank and incineration based heat and power plant driving the absorption heat pumps.



Fig.2: Picture of Thisted Geothermal Plant

3.3 Absorption heat pump concept

Electric heat pumps use a compressor to suck low temperature vapours and extract heat from an evaporator and to compress the vapours and deliver the heat in a condenser at a higher temperature level.

An absorption heat pump is driven by heat instead of electricity and the **type** used in Thisted uses a LiBr-water mixture to suck vapours from the evaporator instead of a compressor.

The ratio between driving heat and extracted heat is nearly constant under different operating conditions. An example of possible operating temperatures and heat effect ratios for absorption heat pumps is shown in Fig.3.

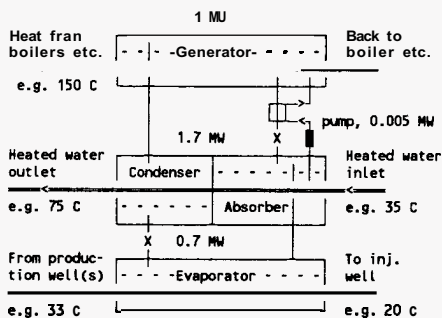

Fig.3: Absorption heat pump concept

The evaporator temperature depend on the heated water outlet temperature, but mainly on the heated water inlet temperature. Typical evaporator temperatures are 15-25°C.

The heated water inlet temperature does normally follow the return temperature on the district heating network, but it may be lowered by a **separate hot water** exchanger. The heated water outlet temperature does normally follow the supply temperature on the district heating network **reduced** by the temperature level increase from other heat producers.

The absorption heat pump consists of an evaporator extracting the geothermal heat, a generator receiving the driving heat for the heat pump and an absorber and condenser delivering all the received and extracted heat to the district heating water.

The evaporator contains pure water evaporating when the LiBr-water mixture in the absorber sucks water vapours from it.

The absorber delivers the absorption heat to the district heating water and the LiBr-water solution is diluted by the absorbed water. A circulation pump circulates the LiBr-water mixture between the absorber and the generator. The generator boils the LiBr-water mixture. The produced water vapour goes to the condenser, where the heat is released to the district heating water. The condensed water returns to the evaporator.

The temperature of the driving heat can be as low as 120°C but 140-160°C driving heat should be used to avoid otherwise occurring limitations in the performance of the LiBr heat pump. The driving heat can be supplied from new or existing heat suppliers to the district heating network - e.g. from district heating boilers.

Driving heat for the absorption heat pump supplied from a district heating boiler is fully recovered on the district heating network and thus in principle free. An unmodified boiler supplying driving heat to the absorption heat pump is, however, losing efficiency if the temperature level is increased compared to a heat production directly to the district heating network. This can be avoided by the use of a heat exchanger extracting excess heat from exhaust gases by direct heat exchange with the district heating water.

All together the absorption heat pump concept does not increase, but reduces the demand for boiler capacity on the network. For boilers supplying the driving heat it may, however, require exchange of boilers or modifications on boilers.

3.4 Wells and submergible pump

The production well is a geothermal exploration well to 3.3 km of which only the first 1300 meter are used in the geothermal Demonstration Plant. The deep zones had too low a permeability to be tested. An intermediate 63°C reservoir was as earlier mentioned also tested, but not chosen due to a high fines content and risk of fines migration.

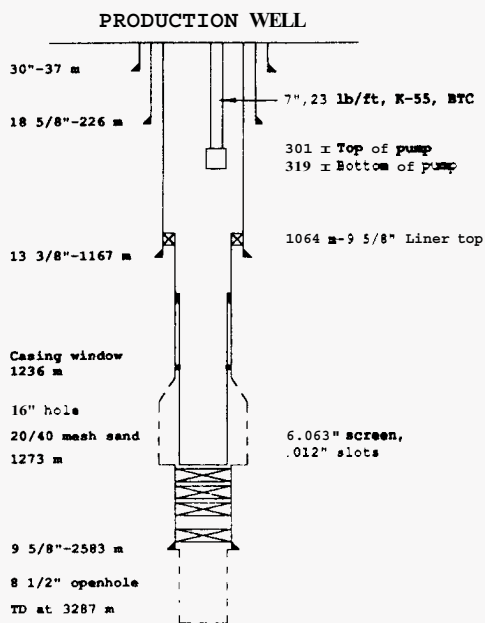

Fig.4: Production well

The submergible electric production pump is placed 200 meter below static water level. The injection well was drilled directly to target reservoir: The Gassum formation at 1250 meters depth.

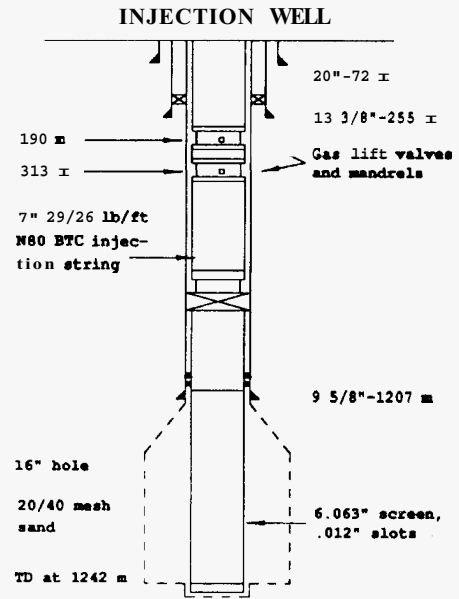

Fig.5: Injection well

Both wells are gravel packed. The injection well is equipped for nitrogen lift clean up. This clean up system has never been used because of the maintained injectivity through all the years. Test results are shown in Table.1.

WELL	YEAR	RESERVOIR	TDS g/l	pH	TEMP. C	DARCY METER
Production	1982	Skagerak, 2.9 KM	288	6.3	-	< 1
		Skagerak, 1.9 KM	170	6.5	63	20-80
		Gassum, 1.2 KM	ion	5.4	46	100
Injection	1983	Gassum, 1.2 KM	-	-	-	110

Table 1: Thisted well test results

3.5 Control and safeguarding system

The geothermal plant is controlled by a computer based control and data collection system and a relay based safeguarding system. The plant is stopped each spring and restarted each autumn.

The control system starts and stops the plant automatically (except for manual check of clean water through filter coupon tests). In the starting procedure:

- The submergible pump is started with an open valve to the basin at the production site. Part of the water is returned to the well annulus to reduce the flow to the basin. The water in the basin is degased and the water lead to the sewer.

Clean water is awaited (e.g. after two hours) and the main flow is redirected through the plant to the injection site basin, where the water is degased and lead to the sewer.

The purity of the water is tested clean by filter coupons before the reinjection starts (e.g. after 24 hours). The injection rate is normally controlled by the flow but switched to pressure control if the pressure drops below a set value. The flow rate set point is adjusted to the recommended working range for the production pump.

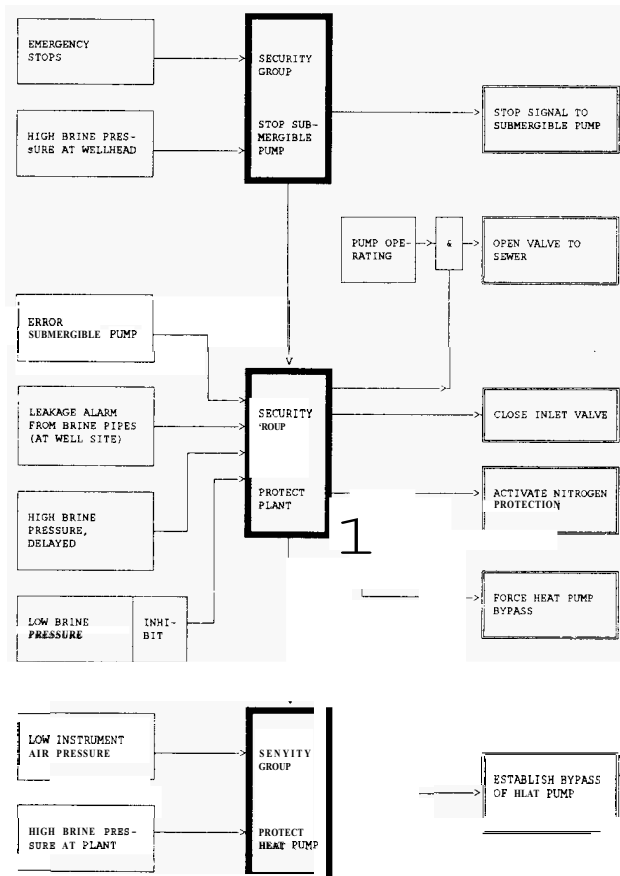

Fig.6: Safeguarding system, Production Plant

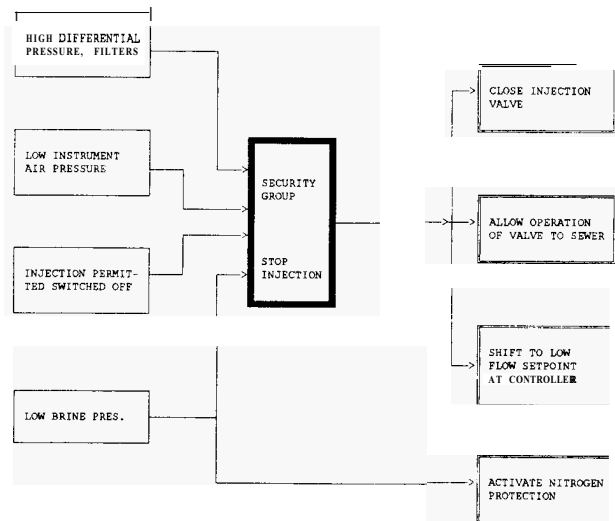

Fig.7: Safeguarding system, Injection Plant

3.6 Operation of plant

Dansk Olie og Naturgas A/S owns the geothermal loop and has the responsibility for operating manuals and solving of problems for it while Thisted Varmeforsyning (the district heating company) owns the rest of the plant and takes care of the daily operation of the plant.

The plant is operated with a computer based data collection and control system and:

- The plant starts and stops computer controlled.

- The system was carefully cleaned before first start up.
- The operating system keeps the pipe system pressurized.
- Overpressure is maintained from nitrogen bottles at stops.
- At restarts the system is cleaned up by pumping the geothermal water to the sewer until the water is clean (checked by filter coupons).

3.7 Gained experience

Together with a low CO₂ content and no H₂S the design and operating concept has lead to corrosion rates below 0.1 mm/year and injection of the 15% saline brine in the sandstone reservoir since 1984 without the use of an injection pump. The present submersible pump at 160 kW has operated without problems since the installation in 1988.

The plant has demonstrated that:

- Energy consumption and operating costs for heat pumps in a geothermal plant can nearly be eliminated by the use of an absorption heat pump.
- It is possible to reinject millions of cubic meters of a 15% saline geothermal water in a sandstone reservoir without the use of an injection pump (the injection well is prepared for clean up operations by nitrogen lift, but it has not yet been needed).
- Corrosion problems and injection problems can be avoided by the concept used in Thisted with nitrogen gas protection, iron tubing, filtering and clean up to a sewer system during start up
- Down time can be reduced to less than one stop per year if the control system has been properly protected against transients from lightning, and if power failures are avoided.
- When the wells are properly completed and the system is cleaned filtering costs for the one micron filters can be reduced to less than one bag filter set per year and one cartridge filter set each second year.

The total increase in injection pressure since 1984 is approx. 2 bar at 140 m³/h (mainly caused by a single short term air leakage in a small hole developed by a faulty welding).

4. HEAT PRODUCTION COSTS

The investment costs in 1986-1988 money for the Thisted Plant are listed below. One DKK is equal to approx. 0.16 US\$ or 0.13 ECU.

Production well	DKK 28.4 million
Injection well	DKK 10.3 million
El. heat pump plant	DKK 3.6 million
Other costs, pilot prod. plant	DKK 1.7 million
Injection pilot plant	DKK 1.1 million
Brine transmission pipe	DKK 2.4 million
New submersible pump, installed	DKK 1.0 million
Expansions, geothermal loop	DKK 1.1 million
Absorption heat pump/boiler unit	DKK 7.1 million
Pipework at heat pump plant	DKK 3.2 million
Power, control system	DKK 1.5 million
Measurements, demo phase	DKK 0.7 million
Properties at wellsites	DKK 0.8 million
Main building, wellhead shelters	DKK 2.4 million
Heat accumulation tank, installed	DKK 0.9 million
Internal adm., miscellaneous	DKK 5.3 million

Total	DKK 71.5 million

The investment costs for the Geothermal plant in Thisted include costs for a 2 km long explorative section in the production well and the Pilot Plant, which is not used in the Demonstration Plant.

The base load on the district heating network in Thisted is covered by the enlarged combined heat and power incineration plant. The remaining heat demand in Thisted is therefore too small to allow production of enough heat to pay back all the investments.

4.1 Normal level for heat production costs

A new geothermal plant at a good location in Denmark may e.g. produce 0.3 million GJ/year heat through 25 years and has the following investment costs:

Production well	2.5 million US\$
Injection well	2.0 million US\$
Surface plant	7.5 million US\$
Total	12.0 million US\$

The investment costs may e.g. be paid through a 25 year loan with 6% real interest (or a 17 year loan with 3% real interest) and the total yearly costs can then become:

Payment on loan	0.9 million US\$/year
Power for pumps etc.	0.2 million US\$/year
Maintenance, adm. etc.	0.4 million US\$/year
Total:	1.5 million US\$/year

The cost per produced GJ becomes US\$ 5 per GJ while repaying the loan (equivalent fuel oil price for oil based heat: 140-150 US\$/ton oil) and US\$ 2 per GJ after the loan is repaid (equivalent fuel oil price for oil based heat: 40-50 US\$/ton oil).

The heat production costs can easily become higher - e.g. in small towns with bad reservoirs. They can, however, also become lower yet - e.g. US\$ 3-4 while repaying the plant loan and US\$ 1-2 per GJ after the loan is repaid.

This can happen if hot springs can be used but also in countries with "normal" temperature gradients (25-35°C/km) if the reservoir is very good and the plant supplies heat to a big district heating network with very low return temperatures. It can also happen if the plant is built using local labour and components in a country with lower cost levels than in Denmark.

4.2 Estimation of concepts and costs

When it is discussed if and where to place geothermal plants it is important to be able to do fast evaluations of heat production costs based on available data. When it is decided to evaluate a specific plant location further and in a design phase it is also important to optimize selection of reservoir, location, flow of geothermal water, number of wells, size of plant, and adjustments to district heating network.

This can best be done through computer simulations of the whole plant including all operation conditions through a year. The model calculates energy balances, sizes components, estimates costs and calculates heat production costs etc.

Dansk Olie og Naturgas has developed a geothermal computer model which also includes simple reservoir simulations. It is used for evaluation of geothermal prospects and to help optimising a plant.

A summary page from this program is included below as an example of very low heat production costs, which are calculated to US\$ 2.9 per GJ while repaying the loan financing the plant and US\$ 1.1 per GJ after the loan is repaid):

AMA, 10/05-1994, 12:58:52, CASE EXAMPLE

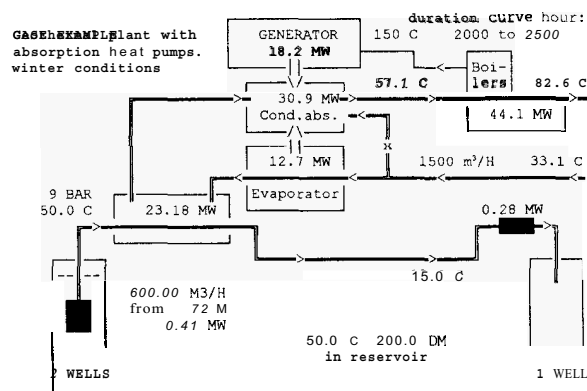

Investment costs in US\$ million:	
Production well, test, misc.	0.92
Injection well, test	0.91
Other geothermal wells	0.72
Production plant	9.57
Injection plant, pipeline	1.13
Adm., design, miscell.	2.28
Building loan costs	1.49
Total,	17.02

At 5 % p.a. real interest during 20 years and 721.2 TJ produced per year:

	US\$ per year	US\$/GJ
Interest and repayment on loan	1.36	1.89
Maintenance, administration	0.44	0.61
Power for heat pumps	0.02	0.03
Power for other pumps etc.	0.32	0.44
Total while repaying loan	2.14	2.97
Total after repay of loan	0.78	1.08

The above calculated low heat production costs are based on a low district heating return temperature, base load operation in a big town, a good reservoir (50°C, 100 m net sand with 2 Darcy permeability) and an area with a low local costs level).

5. COMBINED CONCEPTS

It is possible to integrate geothermal plants with combined heat and power plants. It is also possible to use geothermal plants for storage of heat or removal of CO₂.

The demand for electricity in Denmark and a decision to cover most of the heat demand on district heating networks in larger Danish cities with heat from combined heating and power plants has together with the already made investments in a natural gas network made it difficult to erect new geothermal plants in Denmark.

New concepts respecting the demand for combined heat and power plants were therefore developed. The absorption heat pump in the geothermal plant in Thisted is as earlier mentioned already driven by heat from the incinerating based heat and power plant in Thisted.

The demand for heat on district heating networks is expected to increase if the development of small heat and power generation plants continues and the power generation efficiency continues to rise. This together with the above mentioned other possible combined uses is expected to improve the prospects for future geothermal plants.

A geothermal plant to be used for heat storage can have two production wells. One of the production wells is then always used for production of geothermal water. The other well is sometimes used for reinjection of stored heat and sometimes for production of geothermal or stored heat.

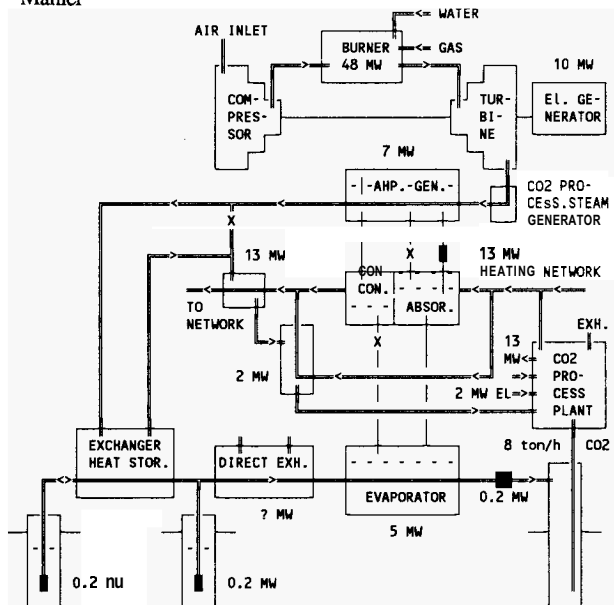

Fig.8: Combined Geothermal Plant with heat and power production, heat storage and CO₂ injection

Liquefied CO₂ can be produced from flue gases using an amine based process. Such a process is described in Hydrocarbon Processing April 1994, page 75.

On this basis the total costs for liquefied CO₂ are calculated to US\$ 30-40 per ton of CO₂. The liquefied CO₂ can be injected cheaply in the injection well of a geothermal plant at e.g. 750 m depth through a small tubing.

The concepts are described in more detail in the other paper for this conference: "Geothermal plant with absorption heat pump in Thisted. Integration with heat and power plant and use for heat storage and removal of CO₂."

6. ENVIRONMENTAL ASPECTS

Geothermal water found in Denmark is basically concentrated sea water. It is thus not allowed to flood farm land or go into the ground water, but small spills are not more harmful than sea water entering rivers, sea water blown across land by the wind or salt used on the roads to prevent ice in winter time.

The geothermal plant in Thisted is constructed with a closed loop and the salty water is not leaked to the ground. Geothermal water which is used to clean up the pipe system before reinjection starts is lead to the sea through the sewer system.

The absorption heat pump does not use CFC-gases, but a LiBr-water solution - and it does thus not leak harmful gases to the atmosphere.

7. ORGANISATION

Dansk Olie og Naturgas A/S was granted a sole concession for the exploration and production of geothermal energy in Denmark in 1978 of which one third of the area was given back to the state in 1993.

The geothermal Pilot Plant was erected and initially also operated by Dansk Olie og Naturgas A/S. The expansion to the present demonstration plant with the absorption heat pump was performed in joint venture with Thisted Varmeforsyning (The district heating company of Thisted owned by the heat consumers).

Thisted Varmeforsyning expanded and operates the heat pump plant with the absorption heat pump assisted by Houe & Olsen, who also designed the integration with the combined heat and power incineration plant. Dansk Olie og Naturgas A/S expanded the geothermal water loop and operates it in cooperation with Thisted Varmeforsyning.

Apart from personnel with specific knowledge about geothermal plants, Dansk Olie og Naturgas A/S employs geologists, geophysicists, reservoir engineers, drilling engineers, facility engineers and economists with expertise within exploration, evaluation, establishment, analysis and operation of geothermal plants.

Dansk Olie og Naturgas A/S cooperates with specialists within Aarhus University regarding reservoir temperature levels, Geological Survey of Denmark and Petroleum Geology Investigators regarding reservoir parameters and has a close cooperation with Houe & Olsen regarding absorption heat pumps and district heating network related problems and geothermal plant erections in general.

A decision to cover the base heat load in larger Danish towns with heat from combined heat and power plants has delayed the further geothermal development in Denmark. Since the erection of the plant in Thisted Dansk Olie og Naturgas A/S has been involved in geothermal investigations outside Denmark In the Kaliningrad Region, Germany, Poland, Latvia and Lithuania and now as manager for the Danish technical assistance to the planned erection of a 600 m³/h geothermal plant in Klaipeda, Lithuania.